



Genuine Parts

INSTALLATION INSTRUCTIONS – Spoiler Harness

1) **DESCRIPTION:** Spoiler Harness

2) **APPLICATION:** Maxima Note: Wire harness pre-wiring is standard on some vehicles. Please check the Accessory Application chart at your local dealership to determine vehicle application. The harness kit is required for installation of rear spoiler on Maxima which is not factory pre-wired for rear spoiler CHMSL.

3) **PART NUMBER:** 999J1 MV0WH

4) **KIT CONTENTS:**

Item	Qty	Description	Part Number
A	1	Electrical Harness	999J1 MV0WH
B	2	Posi-Tap	
C	7	Cable ties 4" black	
D	6	PSA Foam pads 80x60x5	
E	1	Long Cable Tie	

5) **INSTALLATION PROCEDURE**

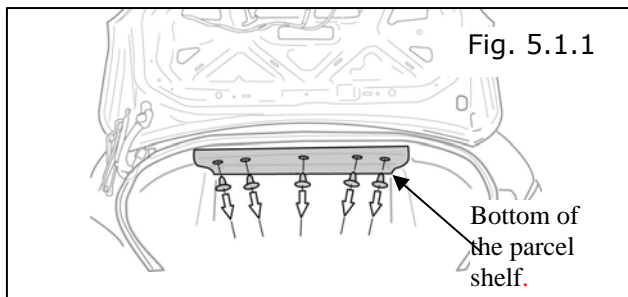

a) Remove the carpeted panel from the bottom side of the parcel shelf. (Fig 5.1.1)

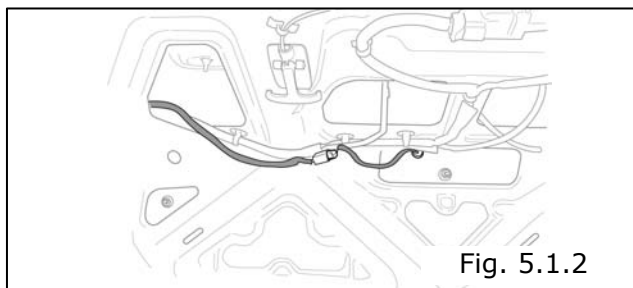

b) Connect the spoiler harness to the harness in the harness install kit.
c) Route the attached harness along the inner panel of the deck lid. (Fig 5.1.2)

INSTALLATION INSTRUCTIONS – Harness

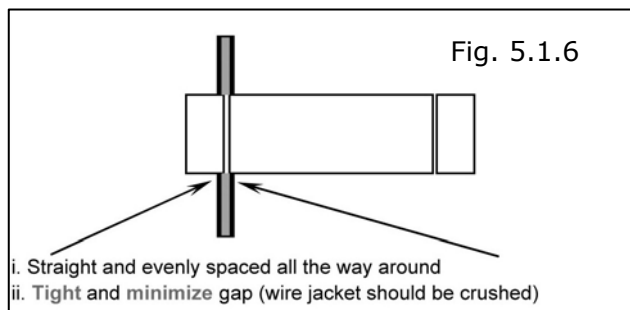
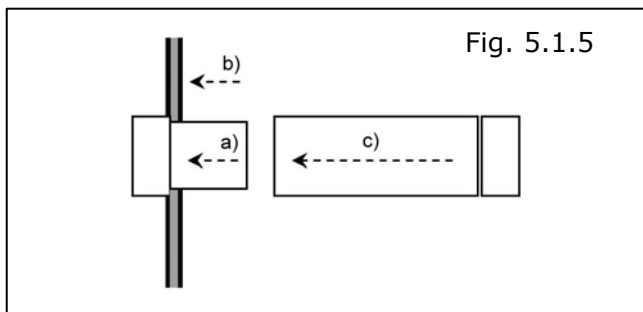
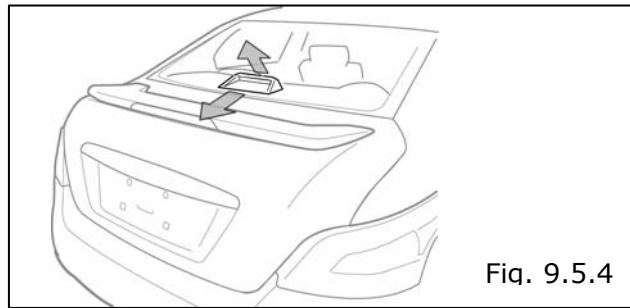
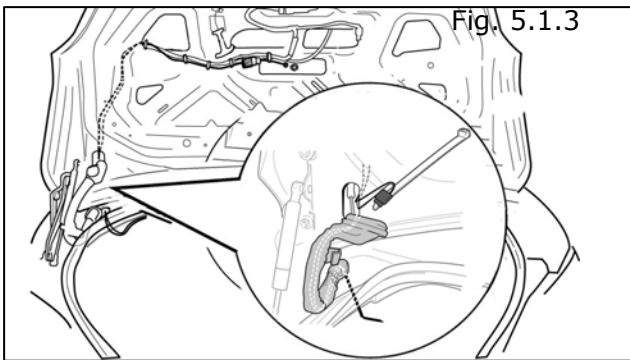

- d) Disconnect both ends of the drivers side rubber boot and disconnect from trunk lid hinge. (Fig 5.1.3)
- e) Take the long cable tie and remove the square end. Attach the stripped wire to the cut end of the wire tie with electrical tape. Feed the cable tie with the wire harness attached in-between the inner and outer deck lid to the boot. Feed the cable tie into and through the boot. Continue threading the wire harness with the cable tie into the main cavity of the trunk. (Fig 5.1.3) Connect the rubber boot to the deck lid and body panel. Be sure the boot is completely installed and seated.
- f) Remove the CHMSL assembly from the rear parcel shelf. Grasp the CHMSL assembly with both hands on each side of the lamp and push it towards the rear of the vehicle while lifting the front edge. (Fig. 9.5.4)
- g) Disconnect the wire connectors to free the CHMSL assembly.
- h) Run the wire harness up through the rear parcel tray so that the wire harness is accessible from inside the vehicle at the parcel shelf.
- i) Locate the vehicle stop lamp power connector previously connected to the CHMSL and using the Posi-Tap connectors connect the red wire on the harness to the white wire (+) and the black wire on the harness to the black (-) wire.

NOTE: See Posi-Tap instructions below for proper application.

NOTE: Do not cut the factory wiring (the red and white wire should be connect and the two black wires should be connect).

- j) Tap vehicle wire
 - a) Remove cap (slot side) from tap body
 - b) Slide cap around vehicle wire
 - c) Tighten the tap **TIGHT** with finger pressure. (Fig. 5.1.5)
- k) Inspect the tap to ensure correct installation. (Fig. 5.1.6)

NOTE: Avoid putting pressure on the vehicle wire and tap for the rest of the installation.

INSTALLATION INSTRUCTIONS – Harness

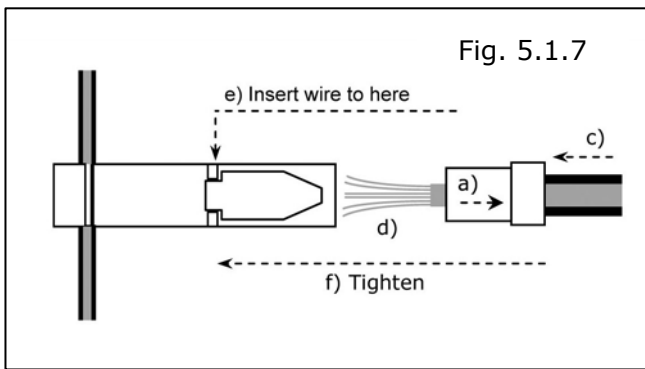

- l) Tap accessory wire. (Fig 5.1.7)
 - a) Remove tap (non-pierce) side from tap
 - b) Remove the protective stub
 - c) Insert wire through the non-pierce side opening
 - d) Spread the individual strands into fan shape
 - e) Insert wire into the tap body and ensure that it is all the way in.
 - f) Tighten the tap **TIGHT** with finger pressure.

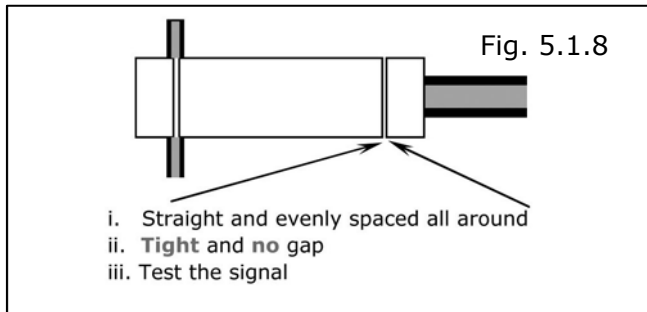

- m) Confirm the tapped accessory wire. (Fig 5.1.8)
 - 1) Inspect the tap to ensure correct installation.
 - 2) Test the signal to ensure that it is working properly.

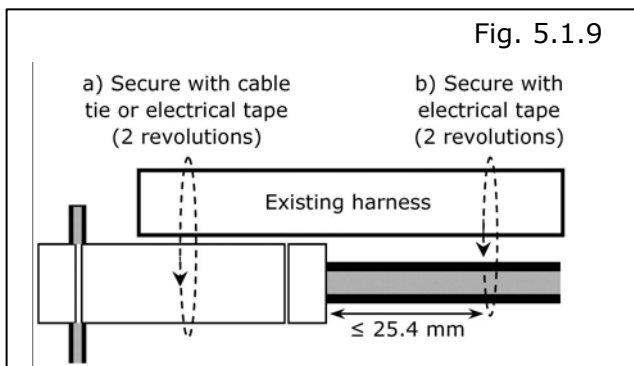

- n) Secure the tap. (Fig 5.1.9)
 - a) Secure the body to an existing anchor point such as harness, clip, metal structure, etc. nearby with cable tie or electrical tape (≥ 2 revolutions), etc.
 - b) Secure the tapped wire on the non-pierce side to an existing anchor point such as harness, clip, metal structure, etc. within 1" (25.4mm) with electrical tape (≥ 2 revolutions).

INSTALLATION INSTRUCTIONS – Harness

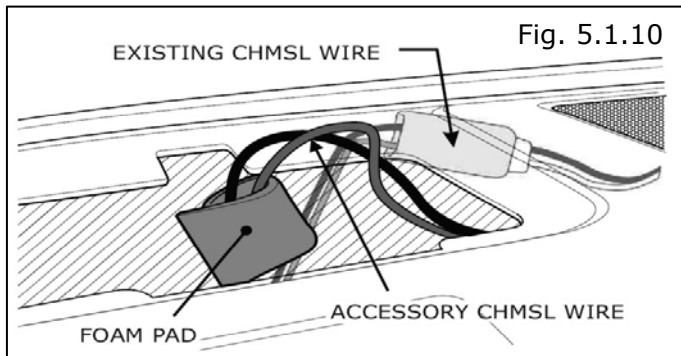

- o) Wrap the connector and Posi-tap connectors with one (1) piece of foam pad. Reconnect the connector and the CHMSL and reinstall the CHMSL back into the parcel shelf. (Fig 5.1.10)

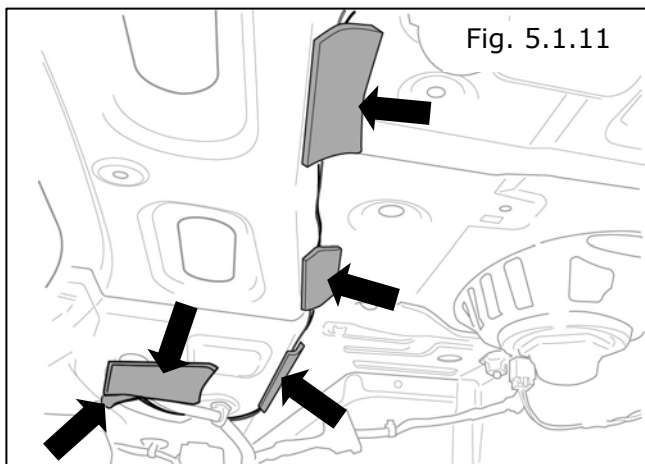

- p) Place foam pads along parcel shelf to hold the harness as shown. (Fig 5.1.11) Be sure to wrap one foam pad over the edge of the harness entry hole.

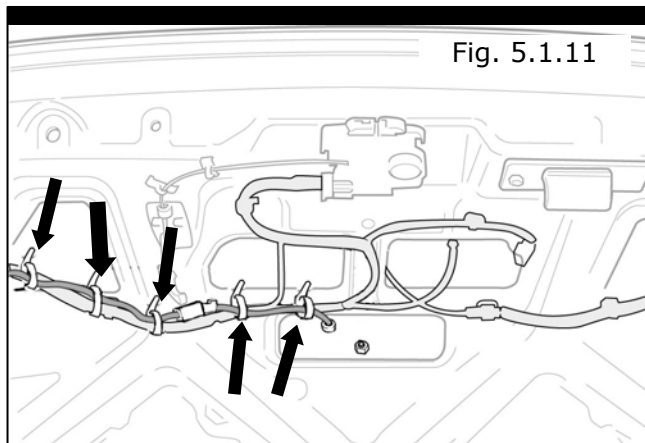

- q) Using the supplied cable ties secure the harness to the deck lid as show in fig. (Fig 5.1.12)
- r) Reinstall the carpeted panel on the bottom of the parcel shelf.
- s) Reinstall the inner liner and bump stops